

CASE STUDY 12

**A PRODUCTIVITY MEETING
ON THE THRUWAY**

I. BACKGROUND INFORMATION

The interaction is between Mr E, the owner of a national office contracting business representing certain office furniture manufacturers, and his son Ernie. It was tape recorded by Ernie with Mr E's permission. Ernie is the respondent.

The interaction is a productivity meeting, i.e., a discussion of what happened during a sales call. The respondent describes the purpose of a productivity meeting as follows:

basically

there are a few things you want to get squared away:

what did we do right in the sale's call

how did we do it right um

if the steps of a sale's call were handled correctly

such as

breaking the ice

um socially

asking probing questions

i.e. about the weather

about sports

then uh

I want to know what I could have done better

could I pick up on things quicker

me being the subordinate

I like to ask him questions

he (boss) answers my questions

more in depth

what I should work on

to eventually do a better job

at your given task

In this case the productivity meeting between MrE and Ernie takes place in their car as they are driving back to Buffalo from Syracuse on the thruway. Ernie is driving. The entire event lasts about 2 hours.

PLACE OF THE SPECIMEN IN ENTIRE EVENT

It seems that the respondent did not chose a single continuous segment of Talk to focus on for in-depth analysis but rather several segments that illustrate how MrE handles E. As a consequence the specimen is constituted by segments of Talk distributed over the entire middle of the event with intervals between them indicated by dots in the table.

These segments occur in 2 main environments:

- 1: in Syracuse
- 2: on the thruway

BEGINNING:	we just came out of the sales call we get into the car to drive home
MIDDLE	<p>Envir.1: in Syracuse</p> <p>· (1-33)</p> <p>·</p> <p>Envir. 2: on the thruway driving along</p> <p>·</p> <p>near rest stop (34)</p> <p>·</p> <p>driving along</p> <p>· (35)</p> <p>· (36-80)</p> <p>· (81)</p> <p>· (82-83)</p> <p>· (84-85)</p> <p>·</p> <p>near toll booth (86)</p> <p>at toll booth (87)</p> <p>driving along (88)</p> <p>·</p>
END:	they arrive at their house in Buffalo

Within these changing environments, it seems that the respondent chose to focus on both contiguous and noncontiguous episodes to illustrate the interaction between MrE and E.

Within environment 1, there is one contiguous episode (1-33).

Within environment 2, on the thruway, there is one clearly contiguous episode (36-80). In addition, the talk in near toll booth (86), at toll booth (87) and driving along (88), seems to be contiguous.

The other episodes seem to be noncontiguous.

II. VERBAL FLOW STRUCTURE

A: SEGMENTATION OF TALK IN SPECIMEN

1) RESPONDENT'S SEGMENTATION:

In his Blow-by-Blow the respondent gives a lengthy commentary of what is taking place in the Specimen. An example is as follows:

we just come out of a sales call
 we get into the car to drive home
 driving
 this is a problem
 because my boss is my father
 he is torn between two roles
 this is why he is yelling at me
 because I'm looking down as I go around a corner

In the Follow-up Interviewing the respondent characterizes the information present in the Specimen on the basis of two notions, **types of talk** and their **relative importance**.

There are three types of talk:

<p>BUSINESS TALK EDUCATIONAL TALK INCIDENTAL TALK</p>
--

Business talk is when they rehash the sale's call that they just attended in Syracuse.

Educational talk is when MrE uses their recent experience to teach his son the business.

Incidental talk is everything else, i.e. unimportant talk. It is sometimes further specified (“family talk”) or intimated (“he yells at me”, “we are at the toll booth”, “we comment on a truck”).

The relative importance of the three types of talk is as follows:

<p>important talk —</p>	<p>BUSINESS TALK</p>
	<p>EDUCATIONAL TALK</p>
<p>unimportant talk: INCIDENTAL TALK</p>	

Transcript of Talk in Specimen as segmented and characterized by respondent

.

.

1: BUSINESS TALK

E (1): well it was a very good call

MrE (2): I left them your conference-table brochures

E (3): well that's okay

(4): it's a good selling point

MrE (5): it's very complete

MrE (6): let me explain to you:

2: EDUCATIONAL TALK

MrE (7): I've never gotten this far with this company before

(8): and I don't want to miss it

E (9): you did a heck of a job

(10): there is a lot of points I've never heard you make before

E (11): Dave is just a designer?

MrE (12): he's okay

(13): he's vice president

3: INCIDENTAL TALK

MrE (14): watch yourself!

(15): watch yourself!

(16): never go around a corner looking down!

4: BUSINESS TALK

E (17): well I'll call back in two weeks to see if we can get in there

(18): this can't work any better for us

(19): their markets are in Syracuse, Rochester and Utica

(20): and that's where we are down

MrE (21): I'll give them an exclusive if that's what he wants

5: EDUCATIONAL TALK

E (22): what were you telling David?

MrE (23): well let's see

(24): that delivery is quick and they can get the bill

(25): then the quicker they can get their commission

(26): that's what it's all about

(27): the line can produce and deliver

6: BUSINESS TALK

E (28): here show this catalog

(29): you can show a number of different people

(30): and suit the different needs

MrE (31): they can't ship in 48 hours

E (32): there aren't many manufacturers that can

(33): anyhow they have a 15/20 discount

.

.

7: INCIDENTAL TALK

MrE (34): pull over at the rest stop!

.

.

MrE (35): you better pay more attention to the road

.

.

8. EDUCATIONAL TALK

MrE (36): Ernie you're going to have to remember
 (37): Kimbal is leaning towards systems
 (38): they have some good deals but they don't do the job
 (39): as they originally did
 (40): when they get into their lower price line
 (41): they go right to National which is their cheap line
 E (42): Is National better than DNS?
 MrE (43): no a little higher priced
 (44): but not the quality of Executive
 (45): they're all committed to systems
 E (46): they're forgetting about their niche
 (47): the area they did so well in
 MrE (48): I'll give you an example:
 (49): there are about 200 manufacturers in systems in the country
 (50): okay?
 (51): everyone feels systems is the wave of the future
 (52): systems are only good in a mass production area
 (53): but they can never replace the executive office
 (54): private place
 E (55): does Kimbal make their own systems?
 (56): or do they buy them?
 MrE (57): they make their own
 E (58): did they just bring it onto the market?
 MrE (59): yes
 (60): they also upset Herman Miller dealers
 E (61): what they're saying is either do our stuff or no one else's
 MrE (62): they are telling them to make a choice

9: INCIDENTAL TALK

E (63): how's it?
 (64): look!
 MrE (65): just drive the car!

MrE (66): this design could have been done for \$400.00 less
 (67): the wall design isn't right
 E (68): for what area?

MrE (69): quit looking over here!
 (70): just drive!

MrE (71): you could have made it with two 60's
 (72): okay?
 E (73): okay
 MrE (74): you have the right idea
 (75): just work with the base
 (76): see there are 12 offices right here
 E (77): yeah
 MrE (78): then what you'll do is put in a work station
 E (79): yeah
 MrE (80): economically the system is better

.

9. INCIDENTAL TALK

MrE (81): stay on the road!

.

.

MrE (82): look at that truck!

E (83): that truck is loaded!

.

.

E (84): hey! did Mom take her shopping spree yet?

MrE (85): yeah

.

.

E (86): Dad, I need money for the toll booth

.

E (87): can I have a receipt

.

10: BUSINESS TALK

E (88): you have to send me ten schematic drawings

.

.

(2) ANALYST'S SEGMENTATION: VERBAL FLOW SECTIONS

The systematization of the respondent's segmentation yields candidate basic units, the Verbal Flow Sections.

They are obtained as follows:

DEFINING CRITERIA for VF 1:

Type of Talk: WORK-RELATED (in 3 Modes: Educational, Rehashing and Neutral)

Modality of Talk: displaced

Focality: focal

SEGMENTATION CRITERIA for VF1 Sections: topics

- the sale's call (1) [Rehashing]
- conference table brochures (2-5) [Rehashing]
- progress accomplished (6-10) [Educational]
- David (11-13) [Educational]
- pursuing advantage (17-21) [Rehashing]
- David again (22-27) [Educational]
- the competition (36-62) [Educational]

DEFINING CRITERIA for VF 2:

Type of Talk: WORK-RELATED (in two Modes: Educational and Rehashing)

Modality of Talk: here-and-now

Focality: focal

SEGMENTATION CRITERIA for VF2 Sections: triggering agents

- catalogue (28-33)[Rehashing]
- picture of fictitious design (66-80) [Educational]
- schematic drawings (88)

DEFINING CRITERIA for VF 3:**Type of Talk:** FAMILY TALK**Modality of Talk:** displaced**Focality:** marginal**SEGMENTATION CRITERION for VF3 Section (84-85):**

topic: Mother

DEFINING CRITERIA for VF 4:**Type of Talk:** ACTIVITY -RELATED**Modality of Talk:** here-and-now**Focality:** marginal**SEGMENTATION CRITERIA for VF4 Sections:** triggering agents

-MrE needs to go to the bathroom (34)

-getting close to tollbooth (86)

-paying toll (87)

DEFINING CRITERIA for VF 5:**Type of Talk:** REGULATING**Modality of Talk:** here-and-now**Focality:** marginal**SEGMENTATION CRITERIA for VF5 Sections:** triggering agents

-E looking down as he goes around a corner (14-16)

-E not paying attention to the road (35), (65), (69-70), (81)

DEFINING CRITERIA for VF 6:**Type of Talk:** EMOTING**Modality of Talk:** here-and-now**Focality:** marginal

SEGMENTATION CRITERIA for VF6 Sections: triggering agents

- car/truck on thruway (63-64)

-a truck passes them on thruway (82-83)

(3) COMPARISON between A's & R's ORGANIZATION

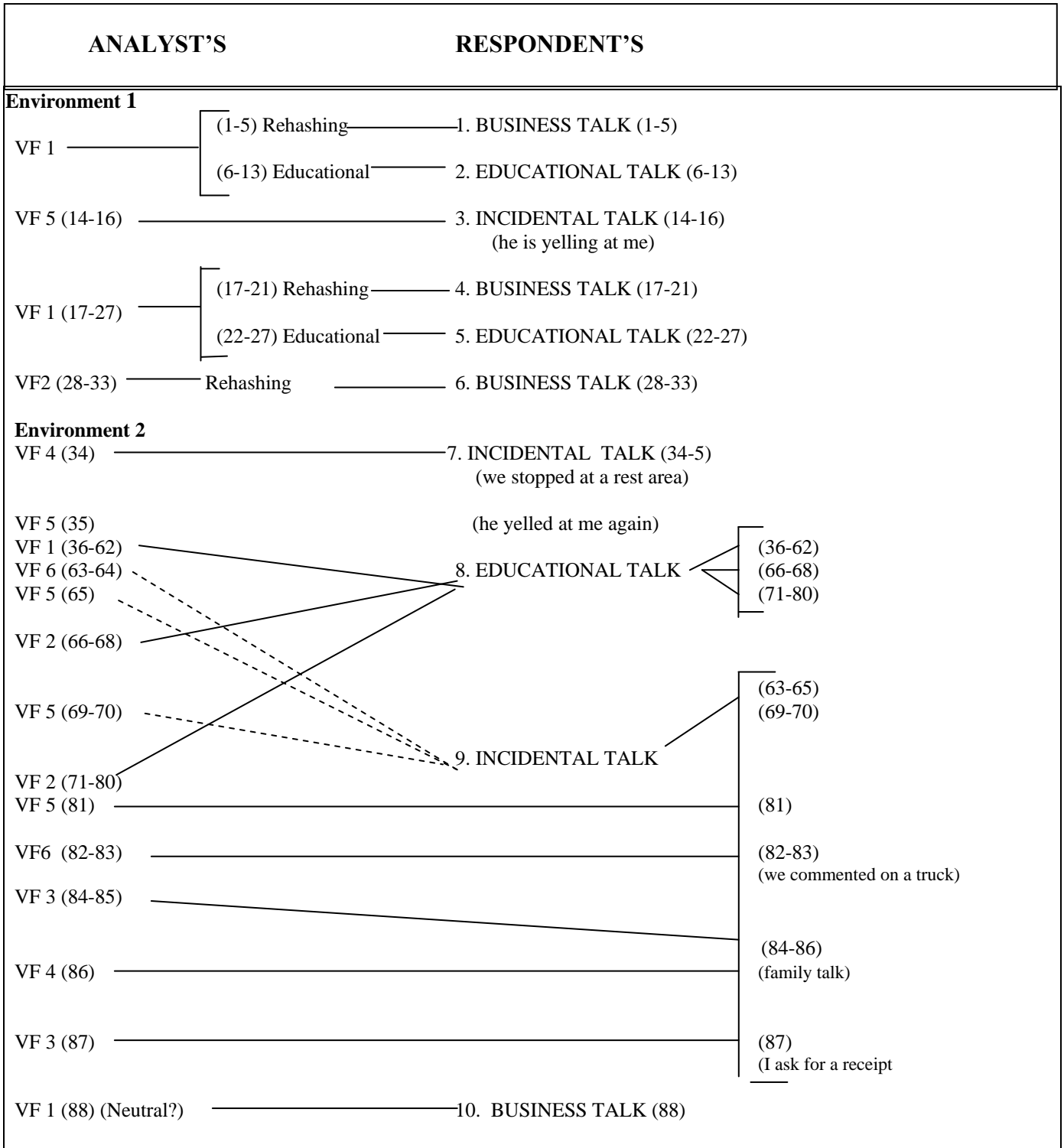

The relationship between the analyst's and the respondent's types of talk is as follows:

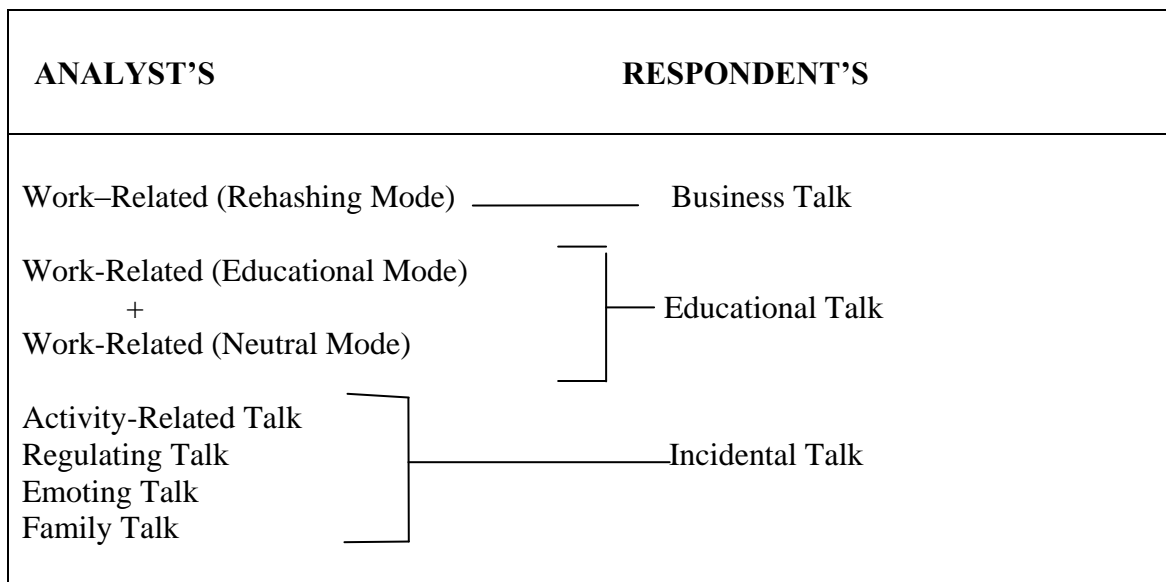

**B: BASIC UNITS: INTERNAL STRUCTURE
and
PARTIAL RHETORICAL ORGANIZATION of
TALK IN CORES**

Each VF Section is now examined in turn in order to ascertain how many basic units it contains. Then, the internal structure of each basic unit, and the partial rhetorical organization of Talk in their respective cores, are described in some detail.

VF SECTIONS IN ENVIRONMENT 1: in Syracuse

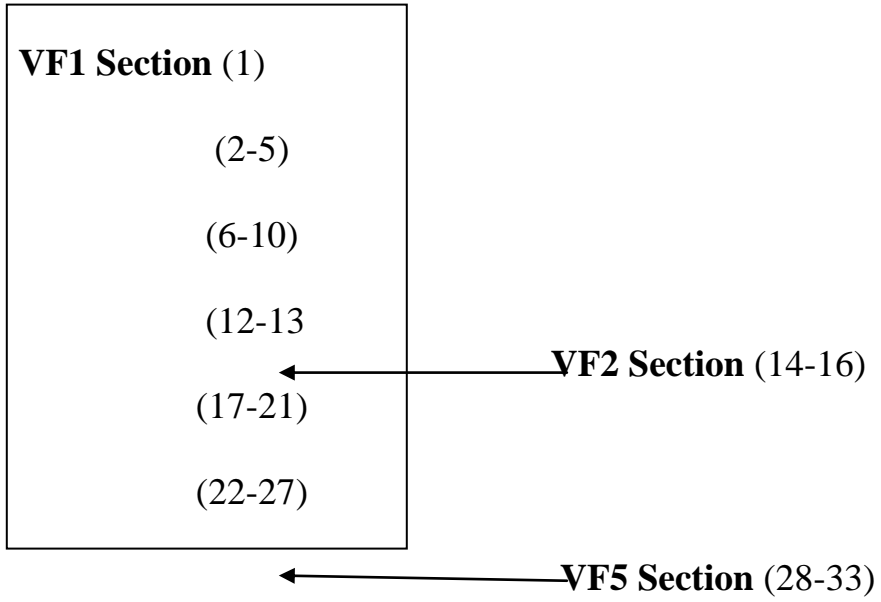

VF1 SECTION (1)

(1) RECAPITULATION

a) Analytic Specification of Section:

Defining Criteria for VF1:

Type of talk: WORK-RELATED (Rehashing Mode)

Modality of Talk: displaced

Focality: focal

Segmentation Criterion for VF1 Section (1):

topic: the sale's call

b) Transcript of Talk in Section:

E (1): well it was a very good call

(2) BASIC UNITS:

There is only one basic unit, VF1 Stretch (1). It is an OFFER, specified by the semantic schema: Ernie's invitation to rehash the sale's call.

(3) DETAILED ANALYSIS OFFER (1)

a) INTERNAL STRUCTURE of OFFER:

The OFFER has only a nucleus. The latter has an entry and a core.

The entry is a univox by E addressed to MrE.

The core is a quasi-exchange initiated by E and addressed to MrE.

NUCLEUS

ENTRY: E (1): well

CORE:

- M1: E to MrE (1)
- M2: MrE: (nonverbal)

b) RHETORICAL ORGANIZATION of CORE:

M1: E's invitation to MrE

invitation proper:

(1) it was a very good call¹

M2: MrE's rejection of invitation

Respondent's account:

fn1

(1) statement

VF1 SECTION (2-5)

(1) RECAPITULATION

a) Analytic Specification of Section:

Defining Criteria for VF1:

Type of Talk: WORK-RELATED (Rehashing Mode)

Modality of Talk: displaced

Focality: focal

Segmentation Criterion for VF1 Section (2-5):

topic: conference table brochures

b) Transcript of Talk in Section:

MrE (2): I left them your conference-table brochures

E (3): well that's okay

(4): it's a good selling point

MrE (5): it's very complete

(2) BASIC UNITS:

There is only one basic unit, VF1 Stretch (2-5). It is an INFORMING, specified by the semantic schema: MrE tells Ernie about the conference table brochures.

(3) DETAILED ANALYSIS of INFORMING (2-5)

a) INTERNAL STRUCTURE of INFORMING:

The INFORMING has a nucleus and a satellite.

The nucleus has only a univocal core by MrE addressed to E.

The satellite is a dyadic remark initiated by E.

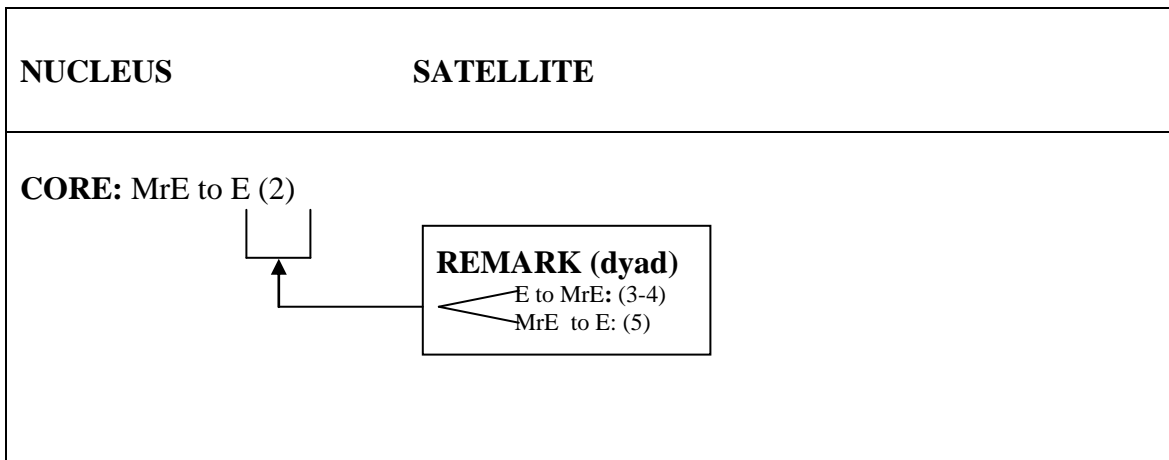

b) RHETORICAL ORGANIZATION of CORES:

MrE's informing to E:¹

(2) I left them your conference-table brochures

REMARK (dyad)

E's confirmation

initiation:

(3) well

development

•1: confirmation proper: ²

(3) that's okay

•2: elaboration (positive assessment):³

(4) it's a good selling point

MrE expending E's elaboration:⁴

(5) it's very complete

Respondent's account:

-fn1

(2) statement

-fn2

(3) confirmation

-fn3

(4) elaboration

-fn4

(5) further elaboration

VF1 SECTION (6-10)

(1) RECAPITULATION

a) Analytic Specification of Section:

Defining Criteria for VF1:

Type of talk: WORK-RELATED (Educational Mode)

Modality of Talk: displaced

Focality: focal

Segmentation Criterion for VF1 Section (6-10):

topic: Need to pursue progress made with company they visited

b) Transcript of Talk in Section:

MrE (6): let me explain to you:
 (7): I've never gotten this far with this company before
 (8): and I don't want to miss it
 E (9): you did a heck of a job
 (10): there is a lot of points I've never heard you make before

(2) BASIC UNITS:

There is only one basic unit, VF1 Stretch (6-10). It is an INFORMING, specified by the semantic schema: MrE tells E about the need to pursue progress made.

(3) DETAILED ANALYSIS of INFORMING (6-10)

a) INTERNAL STRUCTURE of INFORMING:

The INFORMING has a nucleus and a satellite.

The nucleus has only a univocal core by MrE addressed to E.

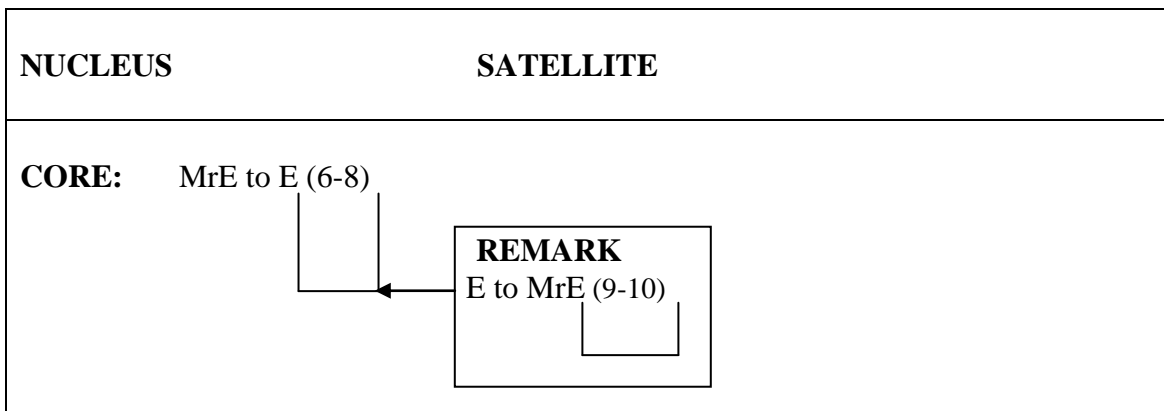

b) RHETORICAL ORGANIZATION of CORE:

MrE's informing to E

- 1: preparation to informing: ¹
(6) let me explain to you:
- 2: informing proper: ²
(7) I've never gotten this far with this company before
- 3: elaboration:
(8) and I don't want to miss it

REMARK

E's approval

- 1: approval proper (1): ³
(9) you did a heck of a job
- 2: elaboration: ⁴
(10) there is a lot of points I've never heard you make before

Respondent's account:

-fn1

(6) statement

-fn2

(7-8) explanation

-fn3

(9) approval

-fn4

(10) elaboration

VF1 SECTION (11-13)

(1) RECAPITULATION

a) Analytic Specification of Section:

Defining Criteria for VF1:

Type of Talk: WORK-RELATED (educational mode)

Modality of Talk: displaced

Focality: focal

Segmentation Criterion for VF1 Section (11-13):

topic: Dave

b) Transcript of Talk in Section:

E (11): Dave is just a designer?

MrE (12): he's okay

(13): he's vice president

(2) BASIC UNITS:

There is only one basic unit, VF1 Stretch (11-13). It is a QUERY, specified by the semantic schemas: Ernie asks MrE what Dave's status is.

(3) DETAILED ANALYSIS of QUERY (11-13)

a) INTERNAL STRUCTURE of QUERY:

The DUAL QUERY has only a nucleus. The latter has only a core, a dialogue initiated by E and addressed to MrE, with one exchange.

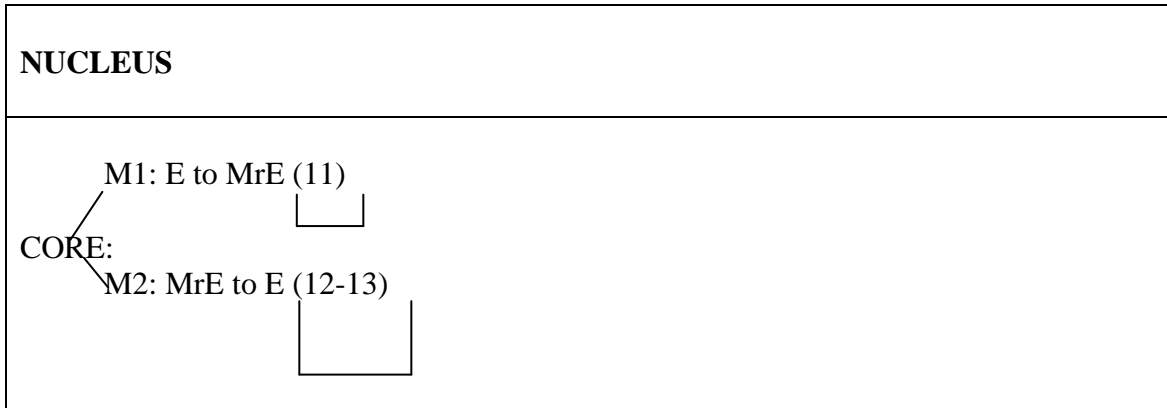

b) RHETORICAL ORGANIZATION of CORE:

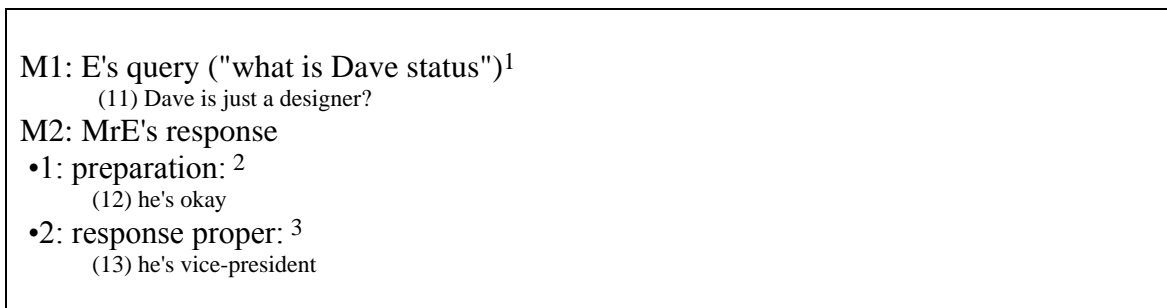

Respondent's account:

- fn1
 (11) statement
- fn2
 (12) confirmation
- fn3
 (13) elaboration

VF5 SECTION (14-16)

(1) RECAPITULATION

a) Analytic Specification of Section:

Defining Criteria for VF5:

Type of Talk: REGULATING

Modality of Talk: here-and-now

Focality: marginal

Segmentation Criterion for VF5 Section (14-16):

triggering agent: E looking down as he goes around a corner

b) Transcript of Talk in Section:

MrE (14): watch yourself!
 (15): watch yourself!
 (16): never go around a corner looking down!

(2) BASIC UNITS:

The Section is constituted by MrE 's verbal responses to the triggering agent: E looking down as he goes round the corner.

There are two basic units, as follows:

- (1) SubStretch F5 (14-15) is a WARNING;
- (2) SubStretch VF5 (16) is an ADMONITION

TRIGGERING AGENT	VERBAL RESPONSES by MrE ¹
E looking down as he goes round the corner	<p>(1) WARNING (univox):² (14): watch yourself! (15): watch yourself!</p> <p>(2) ADMONITION (univox):³ (16): never go around a corner looking down!</p>

Respondent's account:

-fn1

(14-16) he is yelling at me because I'm looking down as I go around the corner

-fn2

(14-15) order

-fn3

(16) explanation

VF1 SECTION (17-21)

(1) RECAPITULATION

a) Analytic Specification of Section:

Defining Criteria for VF1:

Type of Talk: WORK-RELATED (Rehashing Mode)

Modality of Talk: displaced

Focality: focal

Segmentation Criterion for VF1 Section (17-21):

topic: E's plans for pursuing advantage

b) Transcript of Talk in Section:

E (17): well I'll call back in two weeks to see if we can get in there

(18): this can't work any better for us

(19): their markets are in Syracuse, Rochester and Utica

(20): and that's where we are down

MrE (21): I'll give them an exclusive if that's what he wants

(2) BASIC UNITS:

There is only one basic unit, VF1 Stretch (17-21). It is an INFORMING, specified by the semantic schema: Ernie tells MrE about his plans.

(3) DETAILED ANALYSIS of INFORMING (17-21)

a) INTERNAL STRUCTURE of INFORMING:

The INFORMING has a nucleus and a satellite.

The nucleus has an entry and a core, both univoxes, by E addressed to MrE.

The satellite is a univocal remark by MrE addressed to E.

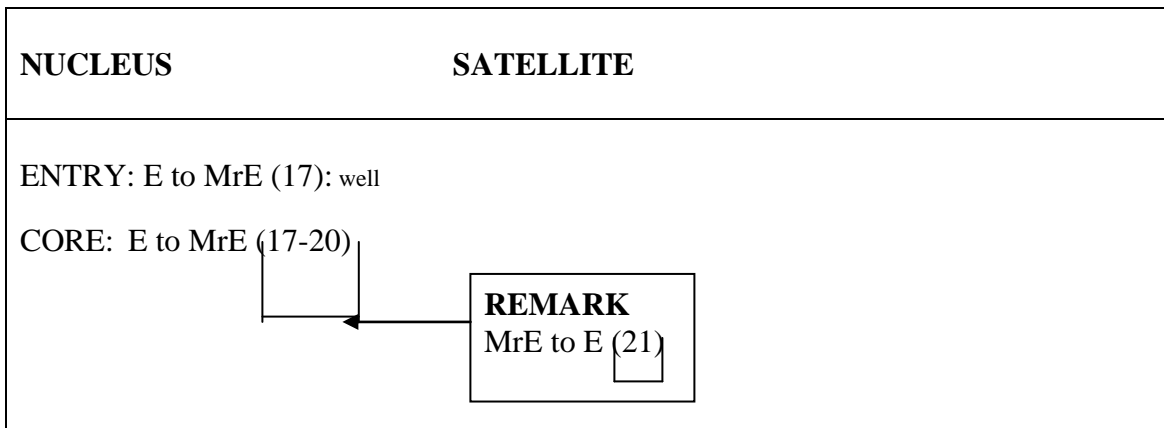

b) RHETORICAL ORGANIZATION of CORE:

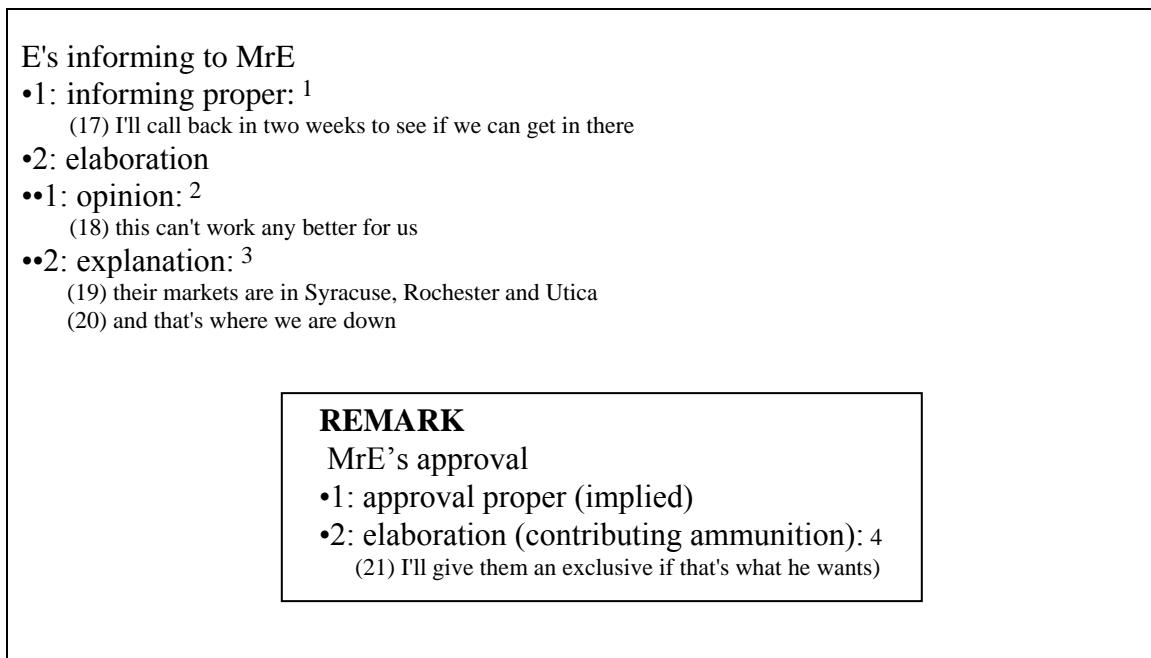

Respondent's account:

-fn1

(17-21)

we discuss the positive points of the sales call

one being the customer has 4 locations throughout the state

we will commit to an exclusive

(17) statement

-fn2

(18) elaboration

-fn3

(19-20) explanation

-fn4

(21) confirmation

VF1 SECTION (22-27)

(1) RECAPITULATION

a) Analytic Specification of Section:

Defining Criteria for VF1:

Type of Talk: WORK-RELATED (Educational Mode)

Modality of Talk: displaced

Focality: focal

Segmentation Criterion for VF1 Section (22-27):

topic: Pursuing the subject of David

b) Transcript of Talk in Section:

E (22): what were you telling David?

MrE (23): well let's see

(24): that delivery is quick and they can get the bill

(25): then the quicker they can get their commission

(26): that's what it's all about

(27): the line can produce and deliver

(2) BASIC UNITS:

There is only one basic unit, VF1 Stretch (22-27). It is a QUERY, specified by the semantic schema: Ernie asks MrE what he told David.

(3) DETAILED ANALYSIS of QUERY (22-27)

a) INTERNAL STRUCTURE of QUERY:

The QUERY has only a nucleus. The latter has only a core, a dialogue initiated by E and addressed to MrE, with one exchange.

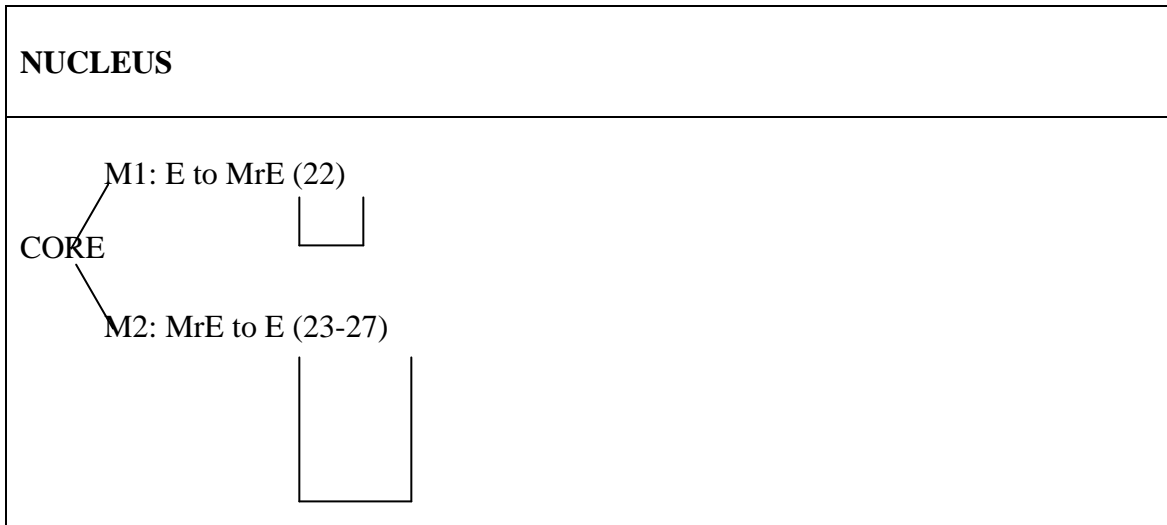

b) RHETORICAL ORGANIZATION of CORE:

M1: E's request for information to MrE: ¹

(22) what were you telling David?

M2: MrE's response

initiation:

(23) well

development

•1: preparation:

(23) let's see ²

•2: answer proper: ³

(24) that delivery is quick and they can get the bill

•3: elaboration:

(25) then the quicker they can get their commission³

(26) that's what it's all about:⁴

(27) the line can produce and deliver⁵

Respondent's account:

-fn1

(22) request for information

-fn2

(23) confirmation (?)

-fn3

(24-25) elaboration (?)

-fn4

(26) explanation

-fn5

(27) further elaboration

VF2 SECTION (28-33)

(1) RECAPITULATION

a) Analytic Specification of Section:

Defining Criteria for VF2:

Type of Talk: WORK-RELATED (Rehashing Mode)

Modality of Talk: here-and-now

Focality: focal

Segmentation Criterion for VF2 Section (28-33):

triggering agent: catalog

b) Transcript of Talk in Section:

E (28): here show this catalog
 (29): you can show a number of different people
 (30): and suit the different needs
 MrE (31): they can't ship in 48 hours
 E (32): there aren't many manufacturers that can
 (33): anyhow they have a 15/20 discount

(2) BASIC UNITS:

The Section is constituted by E and MrE 's verbal responses to the triggering agent: catalog.

There is only one basic unit, VF2 Stretch (28-33). It is an OFFER OF ADVICE, specified by the semantic schema: Ernie gives advice to MrE.

This is shown in the following Table:

TRIGGERING AGENT	VERBAL RESPONSES
catalog	E's OFFER of ADVICE (28-33)

(3) DETAILED ANALYSIS of OFFER of ADVICE (28-33)

a) INTERNAL STRUCTURE OF OFFER of ADVICE:

The OFFER of ADVICE has only a nucleus. The latter has an entry and a core.
The entry is a univox by E to MrE.

The core is a dialogue, initiated by E and addressed to MrE, with one three-member exchange.

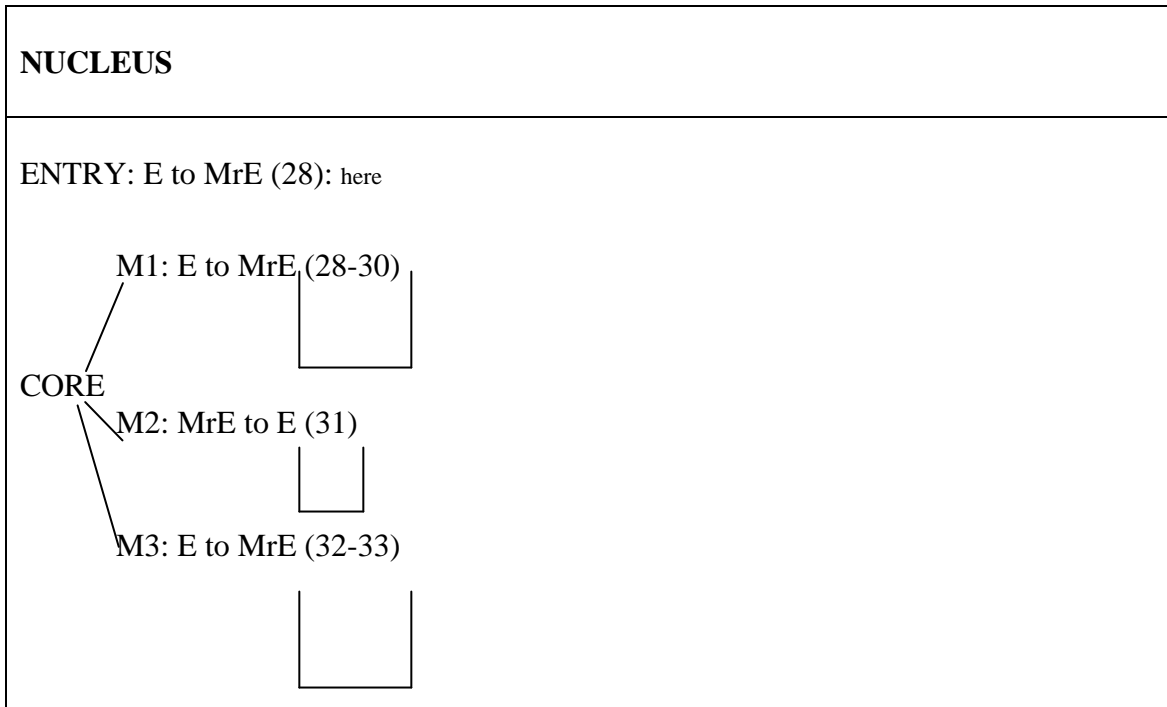

b) RHETORICAL ORGANIZATION of CORE:

M1: E's advice to MrE

- 1: suggestion proper: ¹
(28) show this catalog
- 2: elaboration: ²
(29) you can show a number of different people
(30) and suit the different needs

M2: MrE's rejection of advice (with objection)

- rejection proper: ³
(31) they can't ship in 48 hours

M3: E countering MrE's objection

- countering proper:
 - 1: first argument: ⁴
(32) there aren't many manufacturers that can
 - 2: second argument: ⁵
(33) anyhow they have a 15/20 discount

Respondent's account:

-fn1

(28) statement of advice

-fn2

(29-30) explanation

-fn3

(31) elaboration

-fn4

(32) explanation

-fn5

(33) elaboration

VF SECTION IN ENVIRONMENT 2: near rest stop

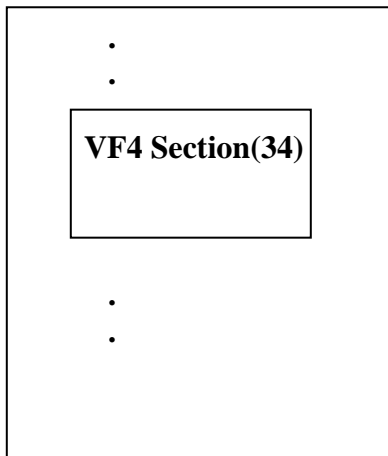

VF4 SECTION (34)

(1) RECAPITULATION

a) Analytic Specification of Section:

Defining Criteria for VF4:

Type of Talk: ACTIVITY-RELATED

Modality of Talk: here-and-now

Focality: marginal

Segmentation Criterion for VF4 Section (34):

triggering agent: MrE needs to go to the bathroom

b) Transcript of Talk in Section:

MrE (34): pull over at the rest stop!

(2) BASIC UNITS:

The Section is constituted by MrE 's verbal responses to the triggering agent: MrE needs to go to the bathroom.

There is only one basic unit, VF4 Stretch (34), It is an ORDER specified by the semantic schema: MrE orders E to stop at the rest area.

This is shown in the following Table:

TRIGGERING AGENT	VERBAL RESPONSES
MrE needs to go to the bathroom	ORDER by MrE to E (34)

(3) DETAILED ANALYSIS of ORDER (34)

a) INTERNAL STRUCTURE of ORDER:

The ORDER has only a nucleus. The latter has only a core, a quasi-exchange, initiated by MrE and addressed to E.

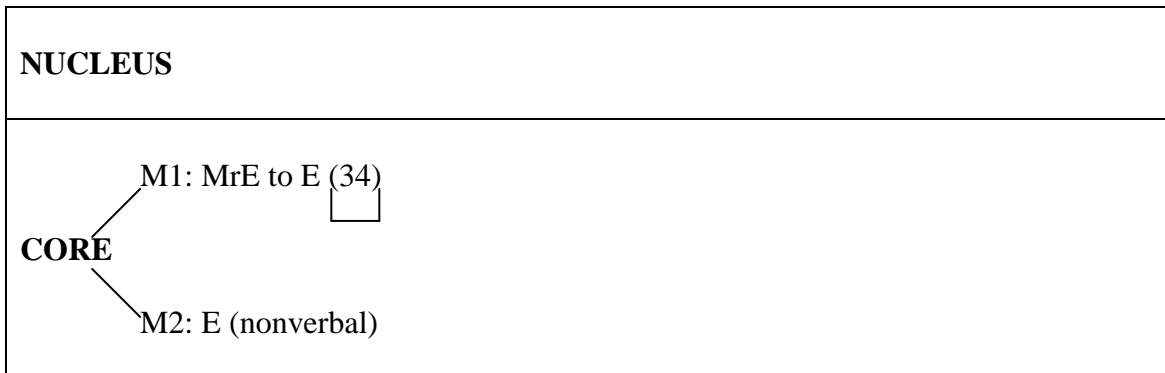

b) RHETORICAL ORGANIZATION of CORE:



Respondent's account:

-fn1

we stopped at a rest area

(34) an order

VF SECTIONS IN ENVIRONMENT 2: driving along

VF5 Section (35)

.

VF1 Section (36-62)

VF6 Section (63-64)

VF5 Section (65)

VF2 Section (66-68)

(71-80)

VF5 Section (69-70)

.

VF5 Section (81)

.

VF6 Section (82-83)

.

VF3 Section (84-85)

VF5 SECTION (35)

(1) RECAPITULATION

a) Analytic Specification of Section:

Defining Criteria for VF5:

Type of Talk: REGULATING

Modality of Talk: here-and-now

Focality: marginal

Segmentation Criterion for VF5 Section (35):

triggering agent: E not paying attention to the road

b) Transcript of Talk in Section:

MrE (35): you better pay more attention to the road!

(2) BASIC UNITS:

The Section is constituted by MrE 's verbal responses to the triggering agent: E not paying attention to the road. There is only one basic unit, VF5 Stretch (35), an ADMONITION.

This is shown in the following Table:

TRIGGERING AGENT	VERBAL RESPONSES
E not paying attention to the road	ADMONITION (univox) MrE (35) you better pay more attention to the road! ¹

Respondent's account:

fn1

(35)

he yelled at me again

told me to pay attention to the road

statement

VF1 SECTION (36-62)

(1) RECAPITULATION

a) Analytic Specification of Section:

Defining Criteria for VF1:

Type of Talk: WORK-RELATED (Educational Mode)

Modality of Talk: displaced

Focality: focal

Segmentation Criterion for VF1 Section (36-62):

topic: the competition

b) Transcript of Talk in Section:

MrE (36): Ernie you're going to have to remember
 (37): Kimbal is leaning towards systems
 (38): they have some good deals but they don't do the job
 (39): as they originally did
 (40): when they get into their lower price line
 (41): they go right to National which is their cheap line
 E (42): Is National better than DNS?
 MrE (43): no a little higher priced
 (44): but not the quality of Executive
 (45): they're all committed to systems
 E (46): they're forgetting about their niche
 (47): the area they did so well in
 MrE (48): I'll give you an example:
 (49): there are about 200 manufacturers in systems in the country
 (50): okay
 (51): everyone feels systems is the wave of the future
 (52): systems are only good in a mass production area
 (53): but they can never replace the executive office
 (54): private place
 E (55): does Kimbal make their own systems?
 (56): or do they buy them?
 MrE (57): they make their own
 E (58): did they just bring it onto the market?
 MrE (59): yes
 (60): they also upset Herman Miller dealers
 E (61): what they're saying is either do our stuff or no-one else's
 MrE (62): they are telling them to make a choice

(2) BASIC UNITS:

There is only one basic unit, VF1 Stretch (36-62). It is a TELLING, specified by the semantic schema: Mr describes the competition to Ernie.

(3) DETAILED ANALYSIS OF TELLING (36-62)

a) INTERNAL STRUCTURE of TELLING:

The TELLING has a nucleus and two primary satellites.

The nucleus has an entry and a core.

The entry is a univox by MrE addressed to E.

The core is a univox by MrE addressed to E.

The first primary satellite is an incidental query. It has only a nucleus. The latter has only a core, a dialogue initiated by E and addressed to MrE, with one exchange.

The second member of the exchange has a satellite, a univocal remark by E addressed to MrE.

The second primary satellite is an incidental query. It has only a nucleus. The latter has only a core, a dialogue initiated by E and addressed to MrE, with two exchanges.

The second member of the second exchange has a satellite, a univocal remark by E, with a univocal co-construction by MrE.

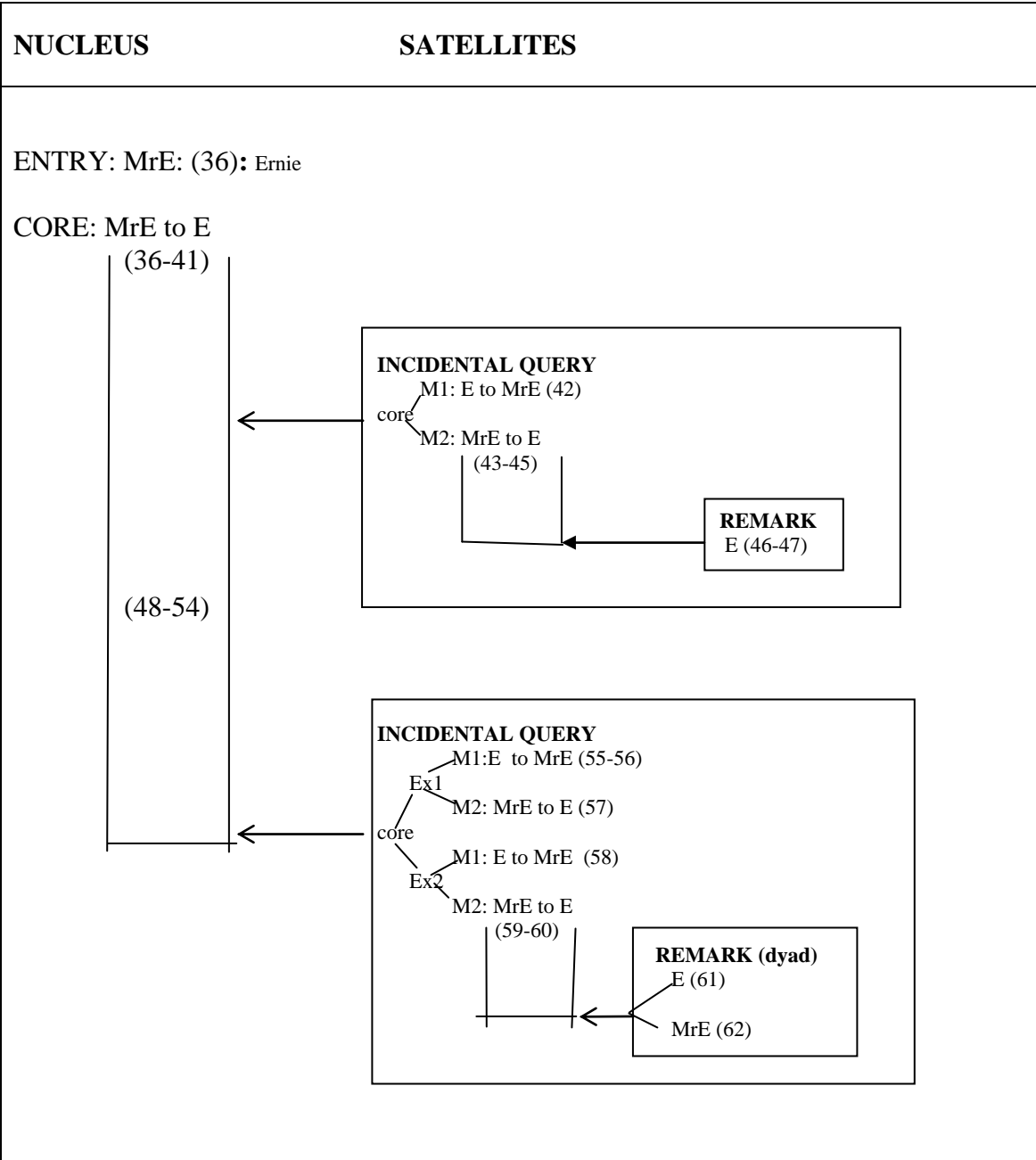

b) RHETORICAL ORGANIZATION of CORES:

•1: MrE telling E about the competition¹

••1: preparation: ²

(36) you're going to have to remember:

••2: telling proper: ³

(37) Kimbal is leaning towards systems

elaboration (explanation): ⁴

(38) they have some good deals but they don't do the job

(39) as they originally did

(40) when they get into their lower price line

(41) they go right to National which is their cheap line

INCIDENTAL QUERY

M1: E's request for information: ⁵

(42) is National better than DNS?

M2: MrE's response ⁶

•1: response proper:

(43) no

•2: elaboration (explanation): ⁷

(43) a little higher priced

(44) but not the quality of Executive

(45) they are all committed to systems⁸

REMARK

criticism of competitors by E:

1.: criticism proper: ⁹

(46) they're forgetting about their niche

2.: elaboration: ¹⁰

(47) the area they did so well in

•2: MrE's illustration

••1: preparation: ¹¹

(48) I'll give you an example:

••2: example proper:

(49) there are about 200 manufacturers in systems in the country¹²

(50) okay¹³

(51) everyone feels systems is the wave of the future¹⁴

(52) systems are only good in a mass production area

(53) but they can never replace the executive office¹⁵

(54) private place¹⁶

INCIDENTAL QUERY

Ex1: initial use of schema

M1: E's request for information: 17

(55) does Kimbal make their own systems?

(56) or do they buy them?¹⁸

M2: MrE's response: 19

(57) they make their own

Ex2: additional use of schema

M1: E's request for information: 20

(58) did they just bring it onto the marker?

M2: MrE's response

•1: answer proper: 21

(59) yes

•2: elaboration: 22

(60) they also upset Herman Miller dealers

REMARK (dyad)

E's explanation: 23

(61) what they're saying is either do our stuff or no one else's

Mr's elaboration: 24

(62) they are telling them to make a choice

Respondent's account:

-fn1

(36-62)

my father is teaching me uh

why these things are positive attributes

my father tells me about the competition

the individual competitors in our market

he narrows the topic

to individual dealers

-fn2

(36) statement

-fn3

(37) statement

-fn4

(38-41) explanation

-fn5
(42) request for information
-fn6
(43) answer
-fn7
(44) elaboration
-fn8
(45) statement
-fn9
(46) statement
-fn10
(47) elaboration
-fn11
(48) statement
-fn12
(49) explanation
-fn13
(50) confirmation
-fn14
(51) elaboration
-fn15
(52-53) explanation
-fn16
(54) elaboration
-fn17
(55) request for information
-fn18
(56) elaboration
-fn19
(57) answer
-fn20
(58) request for information
-fn21
(59) confirmation
-fn22
(60) statement
-fn23
(61) explanation
-fn4
(62) elaboration

VF6 SECTION (63-64)

(1) RECAPITULATION

a) Analytic Specification of Section:

Defining Criteria for VF6:

Type of Talk: EMOTING

Modality of Talk: here-and-now

Focality: marginal

Segmentation Criterion for VF6 Section (63-64):

triggering agent: a car/truck on the thruway

b) Transcript of Talk in Section:

E (63): how's it...?
(64): look

(2) BASIC UNITS:

The Section is constituted by Ernie 's verbal responses to the triggering agent: traffic on the thruway.

There are two basic units, as follows:

(1) VF6 SubStretch (63), an EXCLAMATION OF SURPRISE;

(2) VF6 SubStretch (64), an EXHORTATION.

This is shown in the following Table:

TRIGGERING AGENT	VERBAL RESPONSES
a car/truck on the thruway	<p>(1) EXCLAMATION of SURPRISE (univox): E (63): how's it...?!¹</p> <p>(2) EXHORTATION (univox): E (64): look!</p>

Respondent's account:

fn1

(63) request for information

VF5 SECTION (65)

(1) RECAPITULATION

a) Analytic Specification of Section:

Defining Criteria for VF5:

Type of Talk: REGULATING

Modality of Talk: here-and-now

Focality: marginal

Segmentation Criterion for VF5 Section (65):

triggering agent: E not paying attention to road

b) Transcript of Talk in Section:

MrE (65): just drive the car!

(2) BASIC UNITS:

The Section is constituted by MrE 's verbal responses to the triggering agent: E not paying attention to road.

There is one basic unit, VF5 Stretch (65), an ADMONITION.

This is shown in the following Table:

TRIGGERING AGENT	VERBAL RESPONSES
E not paying attention to the road	ADMONITION (univox): MrE (65): just drive the car! ¹

Respondent's account:

fn1

(65) an order

VF2 SECTION (66-68)+(71-80)

(1) RECAPITULATION

a) Analytic Specification of Section:

Defining Criteria for VF2:

Type of Talk: WORK-RELATED (Educational Mode)

Modality of Talk: here-and-now

Focality: focal

Segmentation Criterion for VF2 Section (66-68)+(71-80):

triggering agent: picture of fictitious design

b) Transcript of Talk in Section:

MrE (66): this design could have been done for \$400 less
 (67): the wall design isn't right
 E (68): for what area?
 MrE (71): you could have made it with two 60's
 (72): okay?
 E (73): okay
 MrE (74): you have the right idea
 (75): just work with the base
 (76): see there are 12 offices right here
 E (77): yeah
 MrE (78): then what you'll do is put in a work station
 E (79): yeah
 MrE (80): economically the system is better

(2) BASIC UNITS:

The Section is constituted by MrE and E 's verbal responses to the triggering agent: picture of fictitious design of systems office divider.

There is only one basic unit, VF2 Stretch (66-68)+(71-80). It is a CRITIQUE, specified by the semantic schema: MrE critiques the fictitious design.

This is shown in the following Table:

TRIGGERING AGENT	VERBAL RESPONSES
fictitious design _____	MrE's CRITIQUE of fictitious design (66-68)+(71-80)

(3) DETAILED ANALYSIS of CRITIQUE (66-68)+(71-80)

a) INTERNAL STRUCTURE of CRITIQUE:

MrE's CRITIQUE has a nucleus and four satellites.

The nucleus has only a univocal core by MrE addressed to E.

-The first satellite is a partial incidental query. It has only a nucleus. The latter has only a partial core, a dialogue initiated by E and addressed to MrE, with one partial exchange.

-The second satellite is a back channel dyad initiated by MrE, the main speaker.

-The third and fourth satellites are two univocal back channel by E responding to MrE.

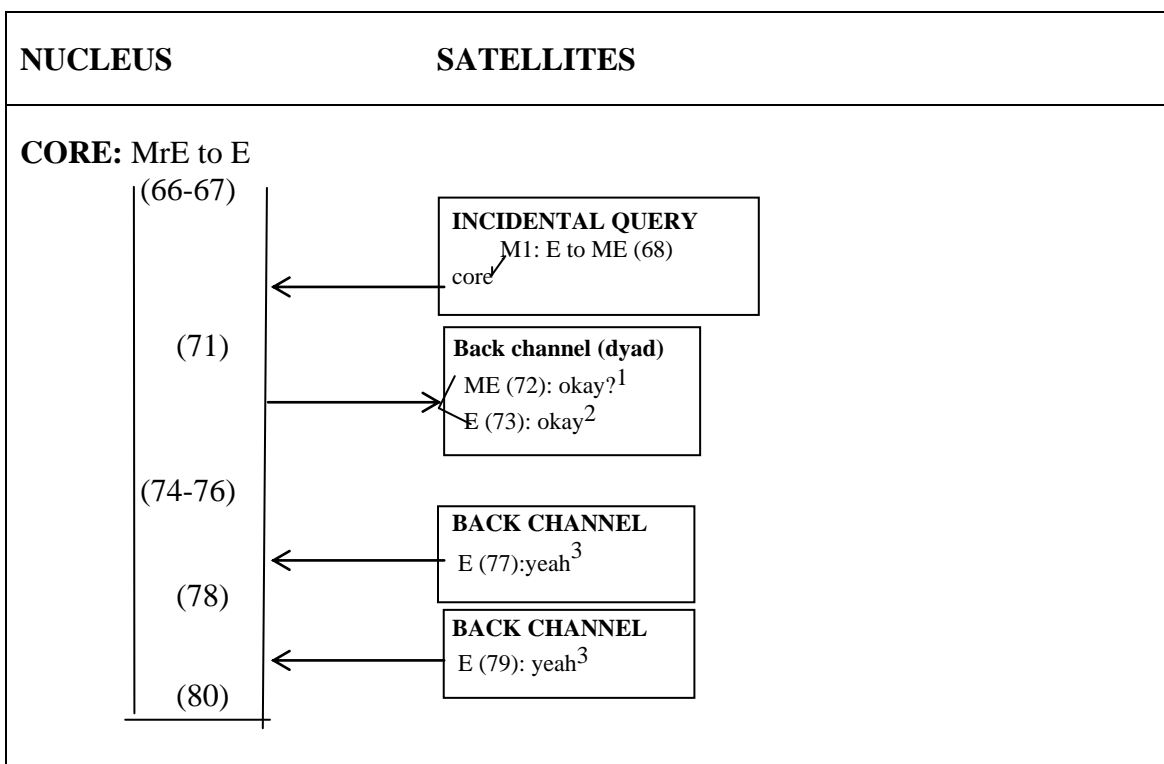

Respondent's account:

-fn1

(72) question

-fn2

(73) confirmation

-fn3

(79) confirmation

b) RHETORICAL ORGANIZATION of CORES:

MrE's critique of E's fictitious design¹

•1: MrE 's evaluation

evaluation proper: ²

(66): this design could have been done for \$400 less

elaboration: ³

(67): the wall design isn't right

INCIDENTAL QUERY

M1: E's request for information (disregarded by MrE): ⁴

(68): for what area?

•2: MrE's revisions⁵:

(71): you could have made it with two 60's⁶

PARENTHESIS

offering support: ⁷

(74): you have the right idea

(75): just work with the base

(76): see there are 12 offices right here⁸

(78): then what you'll do is put in a work station⁹

(80): economically the system is better¹⁰

Respondent's account:

-fn1

(66-80)

now we discuss an independent product line

which is systems

office dividers

I had to show him a fictitious design

(66-67) of course he is making corrections

-fn2

(66) statement of advice

-fn3

(67) elaboration

-fn4

(68) request for information

-fn5

(71+75-80)

he shows me a revised copy of the system

he gives me a visual example of a system

-fn6

(71) statement of advice

-fn7

(74) offering support

-fn8

(75-76) elaboration

-fn9

(78) statement

-fn10

(80) statement

VF5 SECTION (69-70)

(1) RECAPITULATION

a) Analytic Specification of Section:

Defining Criteria for VF5:

Type of Talk: REGULATING

Modality of Talk: here-and-now

Focality: marginal

Segmentation Criterion for VF5 Section (69-70):

triggering agent: E not paying attention to road

b) Transcript of Talk in Section:

MrE (69): quit looking over here!
(70): just drive!

(2) BASIC UNITS:

The Section is constituted by MrE 's responses to the triggering agent: E not paying attention to road.

There are two basic units, as follows:

(1) VF5 Sub Stretch (69), an ADMONITION;

(2) VF5 SubStretch (70), an ADMONITION.

This is shown in the following Table:

TRIGGERING AGENT	VERBAL RESPONSES
E not paying attention to the road	<p>ADMONITIONS (univoxes):</p> <p>MrE { (69): quit looking over there¹ (70): just drive!¹</p>

Respondent's account:

fn1

(69-70) an order

VF5 SECTION (81)

(1) RECAPITULATION

a) Analytic Specification of Section:

Defining Criteria for VF5:

Type of Talk: REGULATING

Modality of Talk: here-and-now

Focality: marginal

Segmentation Criterion for VF5 Section (81):

triggering agent: E not paying attention to road

b) Transcript of Talk in Section:

MrE (81): stay on the road!

(2) BASIC UNITS:

The Section is constituted by MrE 's verbal responses to the triggering agent: E not paying attention to road.

There is only one basic unit, VF5 Stretch (81), an ADMONITION.

This is shown in the following Table:

TRIGGERING AGENT	VERBAL RESPONSES
E not paying attention to the road	ADMONITION (univox): MrE (81): stay on the road! ¹

Respondent's account:

fn1

(81) an order

VF6 SECTION (82-83)

(1) RECAPITULATION

a) Analytic Specification of Section:

Defining Criteria for VF6:

Type of Talk: EMOTING

Modality of Talk: here-and-now

Focality: marginal

Segmentation Criterion for VF6 Section (82-83):

triggering agent: a truck passes them on the thruway

b) Transcript of Talk in Section:

MrE (82): look at that truck!
E (83): that truck is loaded!

(2) BASIC UNITS :

The Section is constituted by MrE and E 's verbal responses to the triggering agent: a truck passes them on thruway.

There are two basic units, as follows:

(1) VF6 SubStretch (82) is an EXHORTATION by MrE;

(2) VF6 SubStretch (83) is an EXCLAMATION by E.

This is shown in the following Table:

TRIGGERING AGENT	VERBAL RESPONSES
a truck passes them on the thruway	<p>(1) EXHORTATION (univox): MrE (82): look at that truck!¹</p> <p>(2) EXCLAMATION of SURPRISE (univox): E (83): that truck is loaded!¹</p>

Respondent's account

fn1

we just commented about a truck

it just passed us

(82) statement

(83) statement

VF3 SECTION (84-85)

(1) RECAPITULATION

a) Analytic Specification of Section:

Defining Criteria for VF3:

Type of Talk: FAMILY TALK

Modality of Talk: displaced

Focality: marginal

Segmentation Criterion for VF3 Section (84-85):

topic: Mother

b) Transcript of Talk in Section:

E (84): hey! did Mom take her shopping spree yet?
MrE (85): yeah

(2) BASIC UNITS:

There is only one basic unit, VF3 Stretch (84-85). It is a QUERY, specified by the semantic schema: Ernie asks MrE about his mother.

(3) DETAILED ANALYSIS of QUERY (84-85)

a) INTERNAL STRUCTURE of QUERY:

The QUERY has only a nucleus. The latter has an entry and a core

The entry is a univox by E addressed to MrE.

The core is a dialogue initiated by E and addressed to MrE, with one exchange.

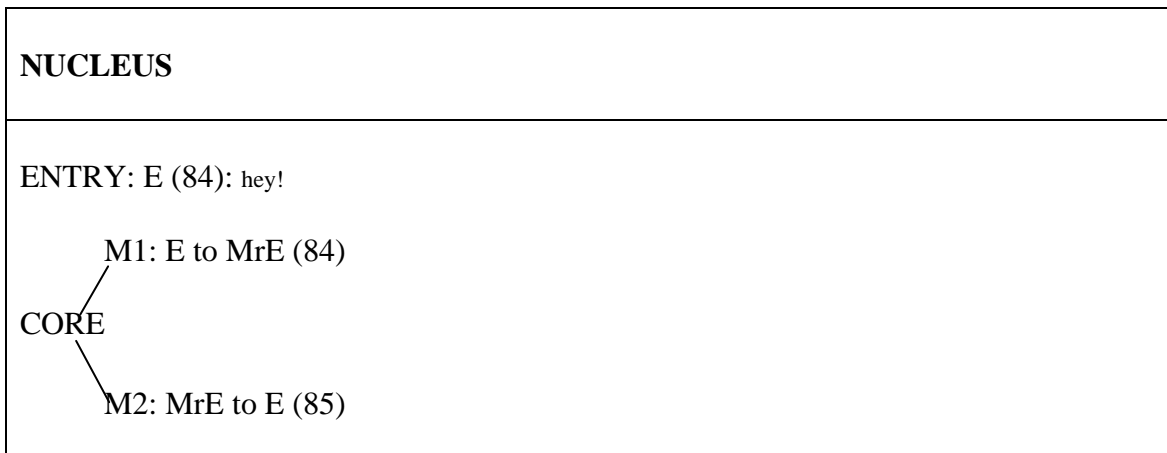

b) RHETORICAL ORGANIZATION of CORE:

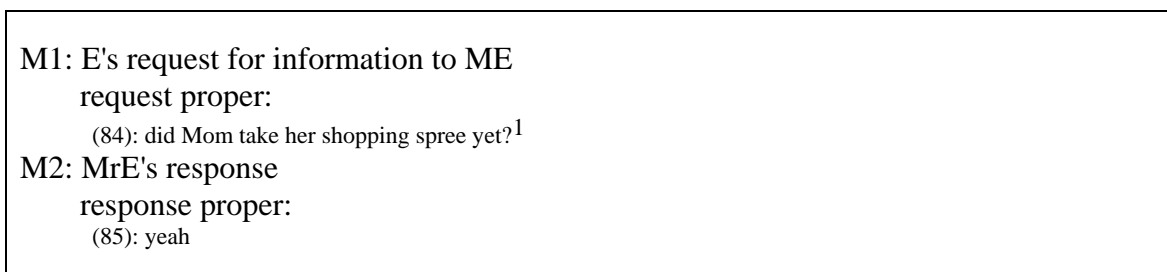

Respondent's account:

fn1

(84) I asked about Mom's shopping spree

VF SECTION IN ENVIRONMENT 2: near the toll booth

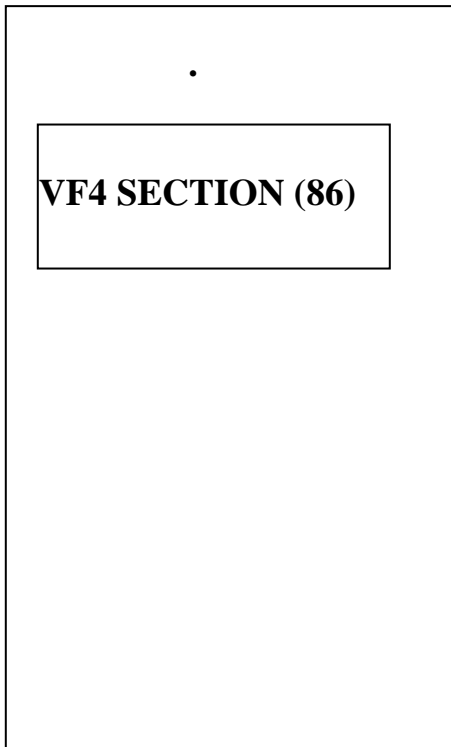

VF4 SECTION (86)

(1) RECAPITULATION

a) Analytic Specification of Section:

Defining Criteria for VF4:

Type of Talk: ACTIVITY-RELATED

Modality of Talk: here-and-now

Focality: marginal

Segmentation Criterion for VF4 Section (86):

triggering agent: getting to toll booth

b) Transcript of Talk in Section:

E to MrE (86): Dad, I need money for the toll booth

(2) BASIC UNITS:

The Section is constituted by E's verbal responses to the triggering agent: getting to the toll booth.

There is only one basic unit, VF4 Stretch (86). It is a DEMAND specified by the semantic schema: Ernie asks MrE for toll money.

This is shown in the following Table:

TRIGGERING AGENT	VERBAL RESPONSES
getting to toll booth	DEMAND by E (86)

(3) DETAILED ANALYSIS OF DEMAND (86)

a) INTERNAL STRUCTURE of DEMAND:

The DEMAND has only a nucleus. The latter has an entry and a core.

The entry is a univox.

The core is a quasi-exchange initiated by E and addressed to MrE.

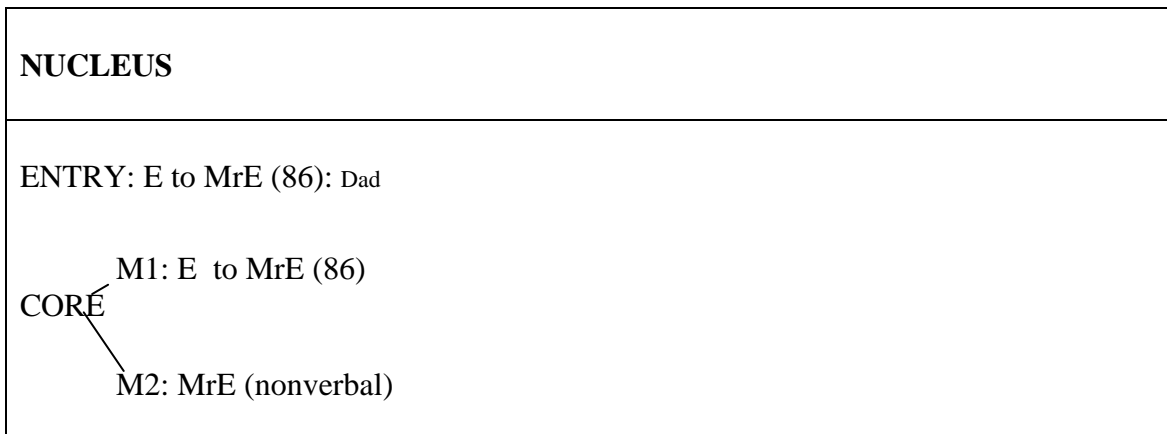

b) RHETORICAL ORGANIZATION of CORE:

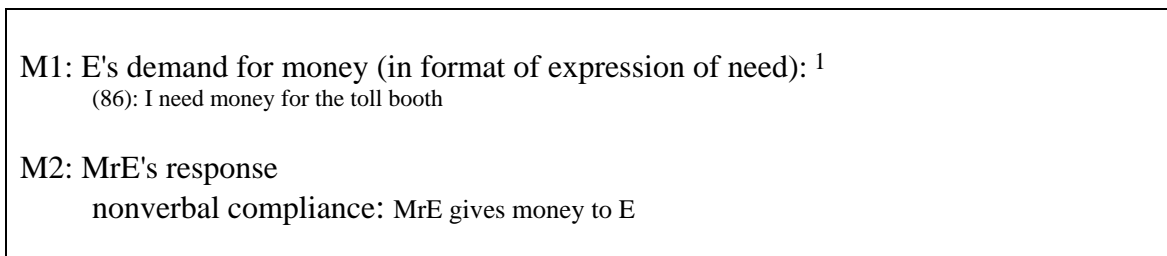

Respondent's account:

fn1

(86) request

VF SECTION IN ENVIRONMENT 2: at toll booth

VF4 SECTION (87)

VF4 SECTION (87)

(1) RECAPITULATION

a) Analytic Specification of Section:

Defining Criteria for VF4:

Type of Talk: ACTIVITY-RELATED

Modality of Talk: here-and-now

Focality: marginal

Segmentation Criterion for VF4 Section (87):

triggering agent: paying toll

b) Transcript of Talk in Section:

E to attendant (87): can I have a receipt

(2) BASIC UNITS:

The Section is constituted by E's verbal responses to the triggering agent: paying toll.

There is only one basic unit, VF4 Stretch (87). It is a DEMAND specified by the semantic schema: Ernie asks attendant for a receipt.

This is shown in the following Table:

TRIGGERING AGENT	VERBAL RESPONSES
paying toll _____	DEMAND by E (87)

(3) DETAILED ANALYSIS of DEMAND (87-87')

a) INTERNAL STRUCTURE of DEMAND:

The DEMAND has only a nucleus. The latter has only a core, a quasi-exchange initiated by E and addressed to the toll booth attendant.

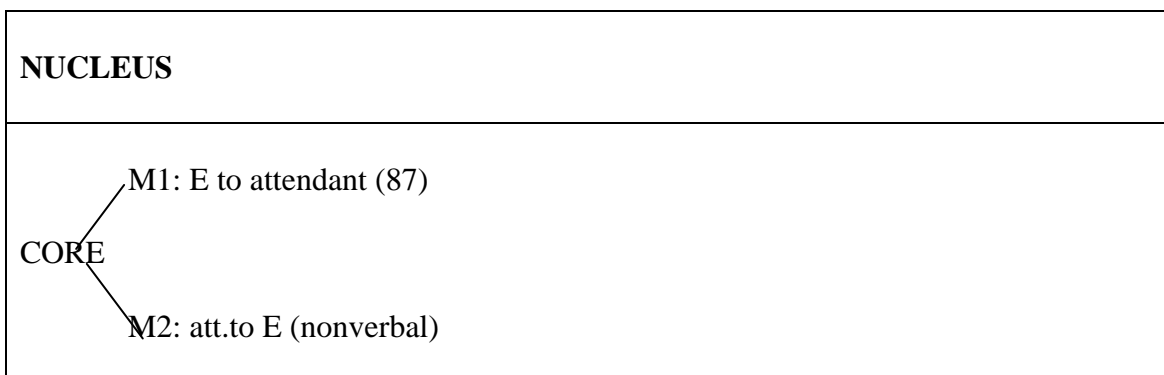

b) RHETORICAL ORGANIZATION of CORE:

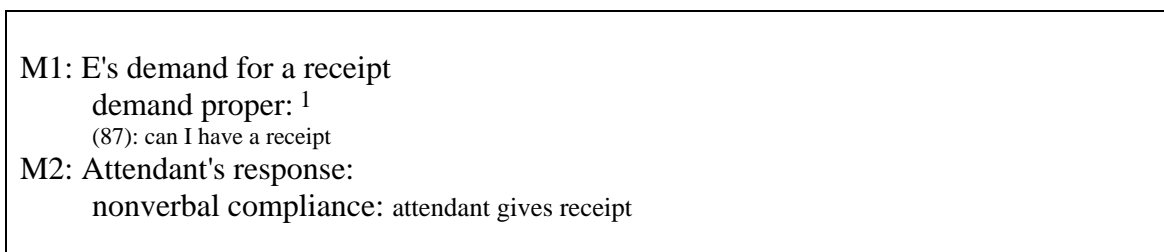

Respondent's account:

fn1

(87)

request:

we're at the toll booth

I ask for a receipt

VF SECTION IN ENVIRONMENT 2: driving along

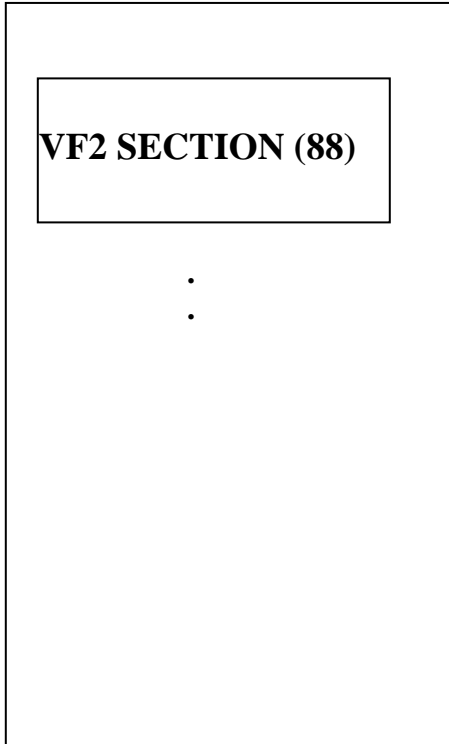

VF2 SECTION (88)

(1) RECAPITULATION

a) Analytic Specification of Section:

Defining Criteria for VF2:

Type of Talk: WORK-RELATED (Neutral Mode)

Modality of Talk: here-and-now

Focality: focal

Segmentation Criterion for VF2 Section (88):

triggering agent: E remembering the schematic drawings

b) Transcript of Talk in Section:

E (88): you have to send me ten schematic drawings

2) BASIC UNITS:

The Section is constituted by E's verbal responses to the triggering agent: E remembering schematic drawings.

There is only one basic unit, VF2 Stretch (88). It is a REMINDER.

It is shown in the following Table:

TRIGGERING AGENT	VERBAL RESPONSES
E remembering the schematic drawings	REMINDER (univox) E to MrE (88): you have to send me 10 schematic drawings ¹

Respondent's account:

fn1

(81)

an order

I have to remind him to send me 10 schematic drawings

I'm sure he will forget

(criticism)

III: INTERACTION CLIMATE

I. INTERACTIVE MODE:

(1) STRATEGY

Ernie is learning the trade by asking his boss/father questions

(2) PARTICIPANT ALIGNMENTS: ROLES

The respondent sees the interaction climate centering around the various roles that his father plays, with the reciprocal roles being implied. As he puts it

this is a problem

because my boss is my father

he is torn between two roles

In the specimen MrE can be said to play 4 different roles: employer, teacher, father and companion, with Ernie playing the following reciprocal roles: employee, learner, child and companion.

The relation between MrE's roles, Ernie's reciprocal roles and the types of talk in the specimen are as follows:

TYPES OF TALK	MrE's ROLES ↔ E's ROLES
Work-Related (Rehashing) (Neutral)	employer ↔ employee
Work-Related (Educational)	teacher ↔ learner
Regulating	father ↔ child
Family Talk Emoting Activity-Related	companion ↔ companion

The reciprocal roles played by MrE and Ernie signal a power/solidarity alignment between them.

The reciprocal roles of employer-employee, teacher-learner, father-child are based on unequal status and signal a power relationship between them.

The reciprocal roles of companion are based on equal status and signal a solidarity relationship between them.

II. REACTIVE MODE: PSYCHOLOGICAL STATES

In one case Ernie expresses his resentment at his employer for being forgetful (88)

DATA FROM RESPONDENT'S ACCOUNT PERTAINING TO INTERACTION CLIMATE

VF5 Section (35)

INTERACTIVE MODE: ROLES

(35)

MrE as disciplinarian vs. E as child

he yelled at me again

told me to pay attention to the road

VF2 Section (66-68)+(71-80)

INTERACTIVE MODE: ROLES

MrE as teacher vs E as learner

(36-62)

my father is teaching me uh why these things are positive attributes

(66-80)

of course he is making corrections

VF3 Section (84-85)

INTERACTIVE MODE: ROLES

E and ME as companions

VF2 Section (88)

REACTIVE MODE: PSYCHOLOGICAL STATES

E is critical of MrE for being forgetful:

I have to remind him to send me 10 schematic drawings

I'm sure he will forget

(criticism)

